

Heat Insulation Analysis of an Aluminum Honeycomb Sandwich Structure
K.Kantha Rao*, K. Jayathirtha Rao

 *Associate Professor, Narsimha Reddy Engineering College, Hyderabad, India
 Director(Retd.), RCI, Hyderabad, India

kkrao_konka@yahoo.com
Abstracts

Heat-transfer has been performed on a sandwich thermal protection system (TPS) for future flight vehicles. The sandwich structures are built from thin walled metal sheets. These structures as a part of the airframe outer cover provide thermal protection to the interior parts mounted inside the vehicle. The temperature protection materials used for sandwich structures should have high strength even at the elevated temperatures. It is easier to simulate the 1500 C temperature on the Aluminum sandwich structures and find the temperature gradient across the sandwich depth. Though the experiment was done on hexagonal cells honeycomb, the ANSYS analyses have been done for both square cell sandwich panel and hexagonal honeycomb panel for comparison. Experiments are done on using Al alloy honeycomb sandwich panels and the validations of experimental work using ANSYS analysis have been performed. ANSYS modeling analysis have been done for both, the square and hexagonal honeycomb sandwich panels of the Al alloy. This paper focus the heat transfer analysis and in exploring the ways to reduce the heat transfer effect with the methods mentioned above, which could be effectively used for flight vehicle applications.

Keywords- Hexagonal core, Square core, aluminum panel, Adhesive, FEA.

Introduction

Sandwich panels are used for design and construction of lightweight transportation systems such as satellites, aircraft, and missiles. Structural weight saving is the major consideration and the sandwich construction is frequently used instead of increasing material thickness, honeycomb are made of very thin material. They reduce the weight, while providing the structural rigidity. This type of sandwich construction consists of two thin facing layers separated by a core material. Potential materials for sandwich facings are aluminum alloys, high tensile steels, titanium, inconel-617 and composites with composites with honeycomb cores and a suitable matrix depending on the specific mission requirement. Several types of core shapes and core materials have been applied to the construction of sandwich structures. Among them, the honeycomb core that consists of very thin foils in the form of hexagonal cells perpendicular to the facings is the most popular.

Honeycomb sandwich structure as shown in fig.1 are currently being used in the construction of high performance aircraft and missiles and are also being proposed for construction of future high speed vehicles. The design of a vehicle for high speed flight must be supported by structural temperature predictions and the amount of heat transferred through the exterior panels during flight. In order to predict these quantities, it is

necessary to have knowledge of the heat transfer characteristics of the honeycomb panel.

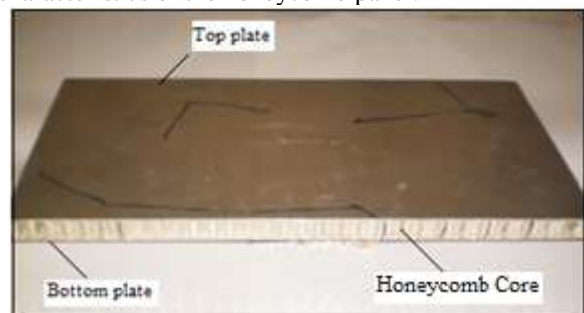

Fig.1 Honeycomb sandwich structure

Honeycomb Structures

In structural sandwiches, face sheets are mostly identical in material and thickness and they primarily resist the in-plane and bending loads. These structures are called symmetric sandwich structures. However, in some special cases face sheets may vary in thickness or material because of different loading conditions or working environment. This configuration is named as asymmetric sandwich structures. In general sandwich structures are symmetric; the variety of sandwich constructions basically depends on the configuration of the core. The core of a sandwich structure can be almost any material or architecture, but in general they are classified in four types, foam or solid core, web core, corrugated or truss core and honeycomb core, the

explored view of the honeycomb core sandwich structure is shown in fig.2. The adhesion of face sheets and core is another important criterion for the load transfer and for the functioning of the sandwich structure as a whole.

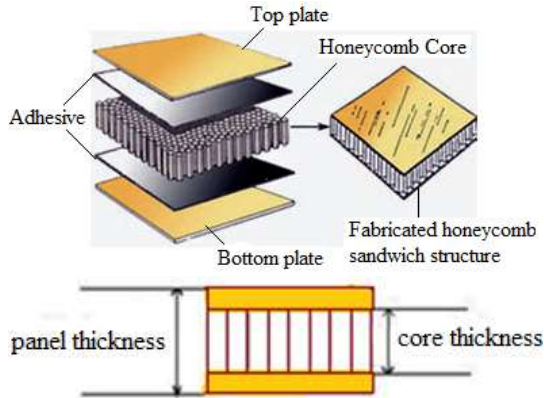

Fig. 2 Exploded view of honeycomb core sandwich structure

Honeycomb Core

The purpose of the core is to increase the flexural stiffness of the panel. The honey comb core as shown in fig.3, in general the core has low density in order to add as little as possible to the total weigh of the sandwich construction. The core must be stiff enough in shear and perpendicular to the faces to ensure that face sheets are constant distant apart to present their detachment.

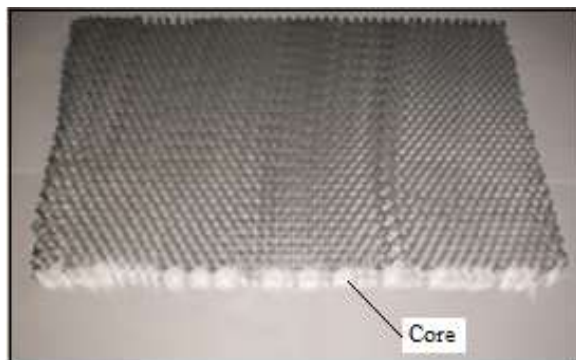

Fig.3 Honeycomb core

High Temperature Adhesives

High Temperature Adhesives find its application mainly in aerospace industries. A number of adhesives available can operate at high temperatures than epoxies and phenolics. These adhesives are really expensive and require high cure temperatures, sometimes complicated cure schedules.

Application Areas of Sandwich Structures

The use of honeycomb sandwich structures in aeronautical and aerospace, applications is getting wider as these structures have excellent stiffness to weight ratios that leads to weight reduction. In aerospace applications various honeycomb cored sandwich structures were used for space shuttle constructions also they are used for both military and commercial aircrafts.

Material properties

The honeycomb panel material was modeled as a sandwich structure with three layers through the thickness. For Aluminum honeycomb panel (upper & lower parts) material is Al-2024 and core material is Al-3003. These properties are summarized in Table-1.

Table- 1 Honeycomb Panel Material Properties

S.No	Properties	Al-2024	Al-3003
1	Thermal Conductivity (W/m ^o c)	121	162
2	Heat Transfer Coefficient (w/m ² -k)	25	25
3	Poisson ratio	0.33	0.33
4	Density (kg/m ³)	2780	2730
5	Specific Heat (j/kg-k)	875	893
6	Thermal Expansion (m/m- ^o c)	22.9x10 ⁻⁶	23.1x10 ⁻⁶

Honeycomb cell geometry

Figure 4 shows two types of honeycomb cell geometry to be analyzed. The honeycomb cell wall thickness for the first two types is t(c). The first type is a right hexagonal cell with identical side lengths of b₁. The second type is a square cell with side lengths of b₂, which is modified from the right hexagonal cell by reducing the bonding interface length to a minimum of $\sqrt{2} t_c$. The size, d(i) (i=1,2) of each type of honeycomb cell is defined as the maximum diagonal of the cell cross section. The size of honeycomb cells types 1, 2, are adjusted to have the same effective density (that is, $\rho_1 = \rho_2$). Honeycomb structures are composed of plates or sheets that form the edges of unit cells. These can be arranged to create, square and hexagonal as shown in fig.6.

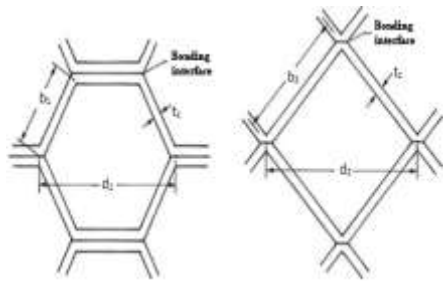

Fig.4 (a) Right hexagonal cell. (b) Square cell
Two-dimension model of Honeycomb Sandwich Structure

In this model, the aluminum honeycomb core was 3003 material and upper & lower plates was 2024 materials, with reduced mass density. Otherwise, the general structure of the sandwich material remained the same, with an aluminum core, trapped between two aluminum plates, with adhesive layers between the two species. Temperature independent values were taken for the conductivity and capacity of the honeycomb-equivalent material, while the properties of the other materials were the same. Fig.5 is a cartoon representing the 2D model implemented in this paper.

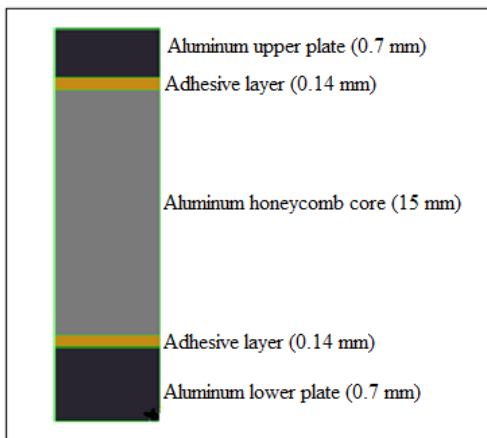

Fig.5 Two-dimension model of Honeycomb Sandwich Structure

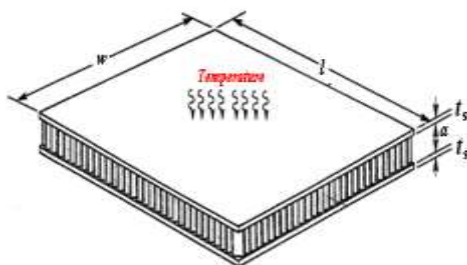

Fig.6 Honeycomb sandwich thermal protection system (TPS) subjected to heating over entire upper surface.

Fig.6 shows a honeycomb-core sandwich thermal protection system panel subjected to transient surface temperature, over its entire outer surface. The thermal protection system panel is rectangular with a side length l & width w , and is fabricated with two identical face sheets with a thickness of t_s and honeycomb core with a depth of a . For a given material, the overall heat-insulation performances of the honeycomb thermal protection system panel depend on the thickness of the face sheets, depth of the honeycomb core, thickness of the honeycomb cell walls, and size and shape of the honeycomb cells,

Numerical Input Values

A typical candidate honeycomb sandwich structures has the following dimensions are given
 $l = 115 \text{ mm}$, $w = 85 \text{ mm}$, $d_1 = 7 \text{ mm}$, $d_2 = 7.42 \text{ mm}$, $b_1 = 3.5 \text{ mm}$, $b_2 = 5.25 \text{ mm}$, $t_s = 0.7 \text{ mm}$, $a = 15 \text{ mm}$, $t_c = 0.005 \text{ mm}$

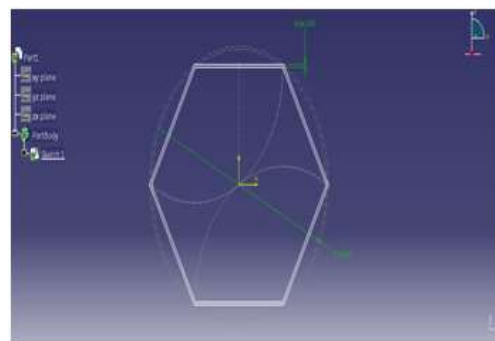

Fig.7 Geometry of Hexagonal Honeycomb Cell

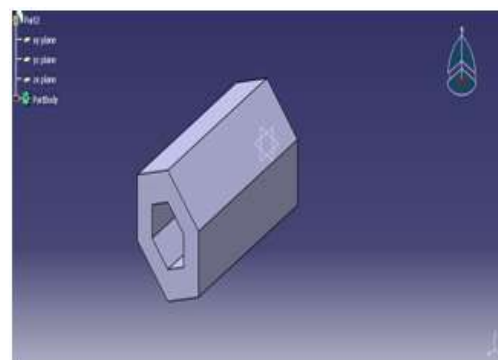

Fig.8 Modeling of Hexagonal Honeycomb Cell

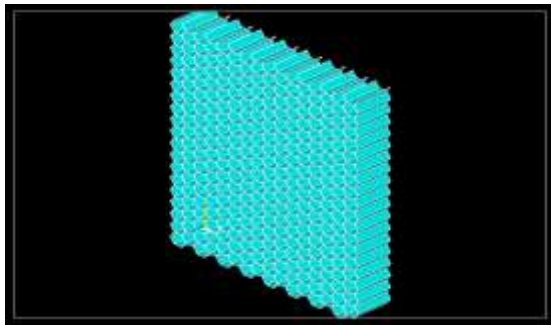

Fig.9 Pattern of Hexagonal Honeycomb Cells

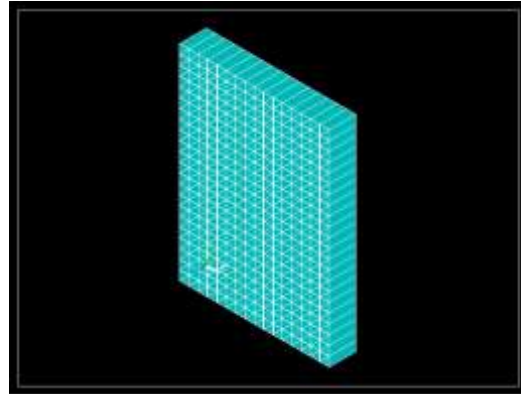

Fig.13 Assembly of square cell

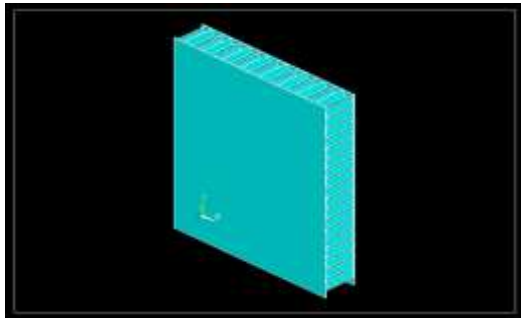

Fig.10 Assembly of Hexagonal Honeycomb cells with structure

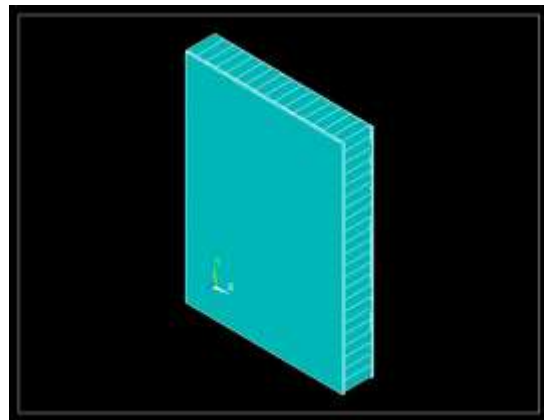

Fig.14 Assembly of square structure with panels

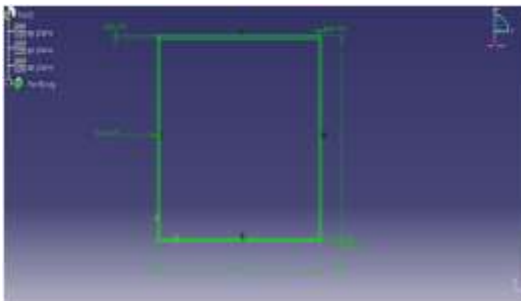

Fig.11 Geometry of Square Sandwich Cell

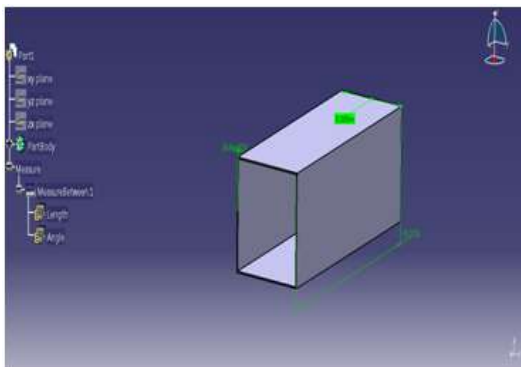

Fig.12 Modeling 3D- Square Honeycomb Cell

Analysis of honeycomb sandwich structure

Heat transfer analysis plays a very important role in the design of many engineering applications. Heat transfer analysis calculates the temperature distribution and related thermal quantities in the system or component. In general, the heat transfer in honeycomb sandwich panels is a result of (1) conduction of heat in the cell walls, (2) radiation interchange within the cell, and (3) convection of heat through the air contained back side of the panel. However, this paper is concerned with sandwich panels in which the primary modes of heat transfer are due to conduction in the cell walls and radiation exchange within the cell. For most honeycomb cores used in the fabrication of sandwich panels, it can be shown that the heat exchange by convection and conduction within the air contained in the cell is negligible compared to conduction in the cell walls and radiation within the cell.

To simplify the analysis, the following assumptions are introduced.

First, honeycomb cells have the same effective density but different geometrical shapes are considered (i.e., hexagon & square shapes).

Second, the effect of internal radiation turned out to be much smaller than that of conduction for the present TPS core geometry, hence radiation can be negligible.

Third, the thermal properties of the materials used do not change with the temperature.

Fourth, there is no convection heat transfer inside the panel, as the experiment will take place inside a still environment. Convection heat transfer is considered for backside of the panel.

Heat Transfer Analysis

Heat transfer is a science that studies the energy transfer between two bodies due to temperature difference. Conductive heat transfer analysis on honeycomb sandwich panels and the tiny volume inside each honeycomb cell, convection heat transfer of the interior air mass were neglected. This section studies the effect of honeycomb cell geometry on the heat-insulating performance of the TPS panel. Before doing analysis to mesh the model so that the effectively find the change in temperature at each and every point. Perform heat transfer analysis under transient state condition.

Transient Thermal Analysis

Transient Thermal Analysis determines temperatures and other thermal quantities that vary over time. Engineers commonly use temperatures that a transient thermal analysis calculates as input to structural analysis evaluations. A transient thermal analysis follows basically the same procedures as a steady-state thermal analysis. The main difference is that most applied loads in a transient thermal analysis are functions of time. To specify time-dependent loads, use both the function tool to define an equation or function describing the curve and then apply the function as a boundary conditions or divide the load-versus-time load into load steps.

Aluminum Hexagonal Honeycomb Sandwich Structure

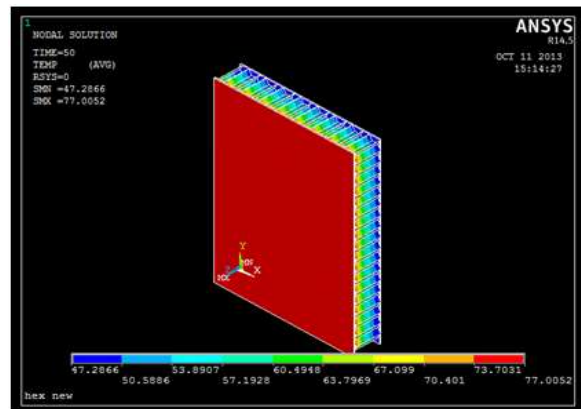
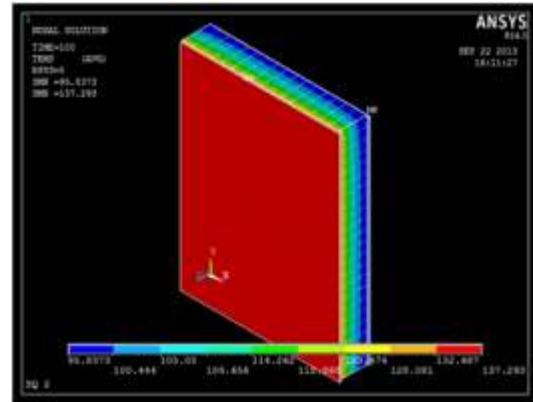

(a) 50 sec

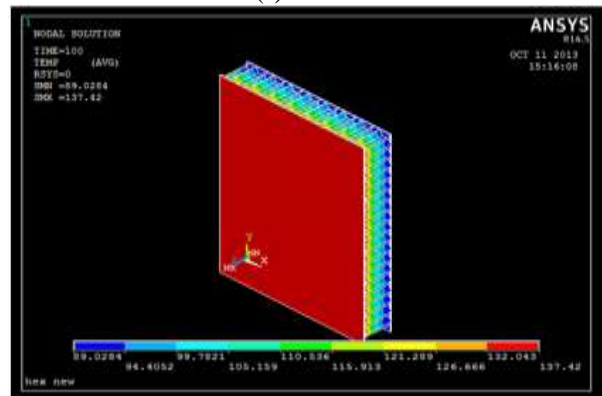

(b) 100 sec

Fig. 15 Temperature distribution with respect to time

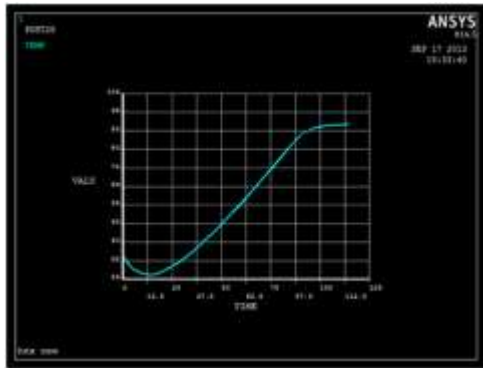
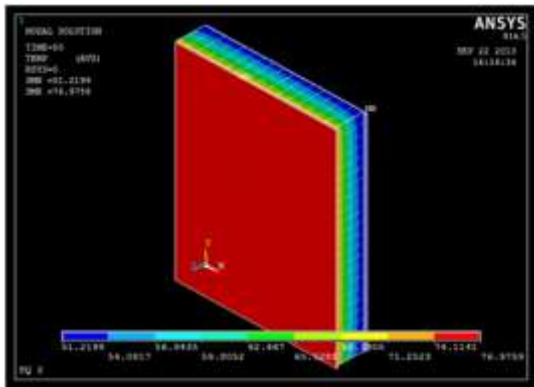

Fig. 16 Aluminum hexagonal honeycomb Sandwich bottom plate temperatures

Aluminum Square Honeycomb Sandwich Structure



(a) 50 sec

(b) 100 sec

Fig.17 Temperature distribution with respect to time

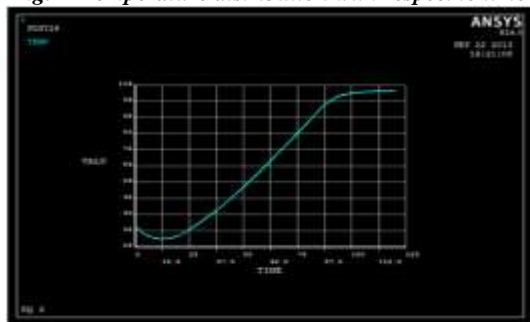

Fig. 18 Aluminum square honeycomb sandwich bottom plate temperatures

Experimental testing

The honeycomb panel and core is mostly empty space. As such, when heat travels through the core, most of it is conducted through the thin walls of the cells, which have a very low area of conductance. This requires a large temperature difference between the two face sheets to move the heat through the core. Also,

because of the empty space, radiation heat transfer is also a factor. Compared to conduction, radiation is a very poor way to move heat around, hence radiation can neglect. How much heat can be shield through the panel is a necessary piece of information when designing heat transfer analysis.

The purpose of this experiment is to determine a way to find the heat insulation performance of an aluminum honeycomb panel when heat is moving through it. The heat transfer analysis of honeycomb sandwich structure specimen at different temperatures was measured with respect to time.

Test Articles

The honeycomb panel test article was designated to simulate the local response near the middle of the lower wing honeycomb sandwich panel skin adjacent to the wheel well. The size of hexagonal sandwich panel is 115 X 85 sq.mm and the height of the core is 15mm and the thickness of the top & bottom plate is 0.7mm. Face sheets are bonded with epoxy adhesive. Aluminum material temperature 150⁰ C limits for usage in Aerospace. The IR (Infrared) lamps are used to heat the specimen plate. The rate of heating is controllable. The thermocouple records the temperature levels on the specimen. The rate of heating is chosen such that the limiting temperature is reached in the time of a couple of minutes, to simulate the aerospace flight environment at high speeds. A Schematic block diagram of the Experimental model as shown in fig.19

Block Diagram

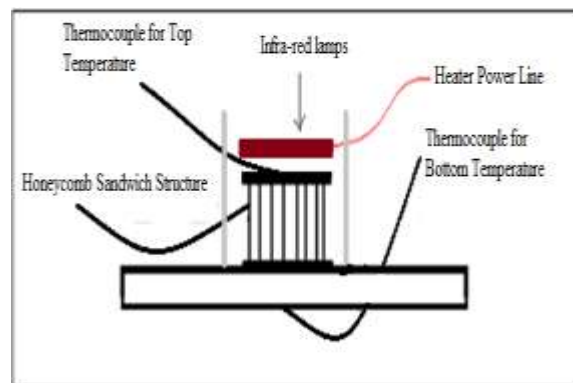

Fig. 19 A Schematic of the Experimental Model

Experimental set –up

The aluminum honeycomb specimen was equipped with four temperature sensors. Two were placed on the upper skin, starting for the both equal sides of the center and two were placed symmetrically on the lower skin. The position of the thermocouples is indicated in Fig.20, with

an order of magnitude for the specimen's dimensions. Fig.20 is a picture of the upper side of specimen, with the TC_s glued (*thermally conductive glue*) and wired. After the sensors were correctly implemented, the heat imposed to the upper surface of the test specimen by changing the temperature is measurements from the thermocouples on the upper and lower skin. A picture of the specimen before testing position with thermocouples and applied both sides' insulations in fig.21.



Fig. 20 Pictures of the specimen before testing with thermocouples



Fig. 21 Picture of the Specimen applied both sides Insulations

The specimen was placed near to infrared lamps, surrounded by zirconium fiber insulations; lower face of the specimen was exposed in air. According to Fourier's Law, The upper face sheet, honeycomb core and lower face sheet of the sandwich structure can be treated as series connection for heat transfer.



Fig. 22 Infra-red lamps, close-up view

5.3 Infra-red lamp cluster

Infra-red lamps, which is generate a controlled temperature over the test specimen. The cluster is composed of a series of infra-red lamps aligned vertically, as depicted in Fig.22. The honeycomb sandwich panel was fixed on a support column, and then placed in front of the lamps. The lamp clusters heat energy emission was controlled such that it created a temperature gradient of 1.3° C/sec over the test specimen. During this experiment, a thermocouple was inserted in the middle of the aluminum honeycomb sandwich panel, and the luminance temperature of the hot surface was measured. As shown in fig.23 heating of the honeycomb sandwich structure.



Fig. 23. Heating of Honeycomb sandwich panel

Various views of heat stopped to the honeycomb sandwich structure as shown in fig.30. Aluminum honeycomb sandwich structure top plate and bottom plate experimental values are plotted in the graph. In this graph maximum temperature difference is 50.58° C at 86.36 seconds as shown in fig.31



Fig. 24 Heat stopped to the Honeycomb sandwich Panel

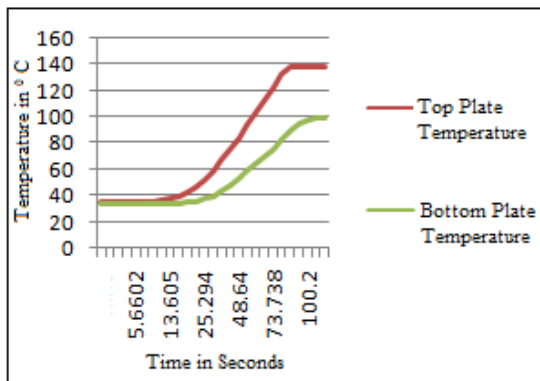

Fig.25 Experimental values for aluminum honeycomb sandwich structure

Results and discussion

The effect of honeycomb cell geometry on the heat-insulating performance of an aluminum alloy TPS has been found out. The results of heat-transfer, of aluminum alloy honeycomb TPS panels are presented in table-2 and table-3 Fig.26 and fig.27 shows the difference between the top plate and the bottom plate temperatures, ΔT is the measure of the heat-insulating performance of the TPS. Namely, the larger the ΔT values of the better the heat-insulating performance. Therefore hexagonal cell geometry reaches maximum 86.36 sec at 50.58°C and square cell geometry reaches maximum 87.13 seconds at 39.91°C then decreases slightly with the increasing time, t. Aluminum hexagonal honeycomb structure for heat insulating is better than square honeycomb structure. The effect of internal radiation turned out to be much smaller than that of conduction for the present TPS core geometry.

Table- 2. Aluminium-Hexagonal Honeycomb Sandwich Structure

Time	TP Temp-	BP Temp- ANSYS	Δt - ANSYS	BP Temp- Experimental	Δt - Experimental
1	35.812	33.2091	2.6029	33.41	2.397
5.6602	35.586	28.2062	7.3798	33.64	1.946
11.59	35.779	26.1249	9.6541	33.67	2.107
15.619	37.969	25.9457	12.023	33.93	4.039
20.876	42.188	27.3743	14.813	34.22	7.968
25.294	46.536	29.5047	17.031	35.15	11.382

Time	TP Temp- ANSYS	BP Temp- ANSYS	Δt - ANSYS	BP Temp- Experimental	Δt - Experimental
30.702	52.204	32.7359	19.468	36.89	15.311
36.514	58.807	36.6954	22.111	39.56	19.241
42.573	66.794	41.3665	25.427	43.23	23.557
48.64	74.974	46.4584	28.515	47.58	27.39
54.834	83.831	51.9596	31.871	52.70	31.126
61.115	93.074	57.793	35.281	58.34	34.734
67.431	102.86	63.9321	38.931	63.75	39.113
73.738	112.43	70.1085	42.321	69.38	43.044
80.045	122.57	76.5323	46.042	75.47	47.102
86.36	132.62	82.9658	49.657	82.04	50.581
92.827	137.47	87.6827	50.145	88.38	48.614
100.2	137.47	89.837	47.363	94.57	42.903
114.96	137.61	90.9112	46.698	98.25	39.359

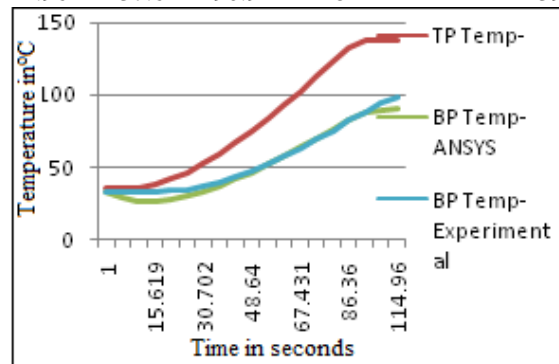

Fig. 26 Effect of hexagonal honeycomb cell geometry on the heat-insulation performance of honeycomb TPS panel

Table- 3 Aluminium-Square Honeycomb Sandwich Structure

Time	TP Temp- ANSYS	BP Temp- ANSYS	Δt - ANSYS
1	35.812	33.4527	2.3593
5.23	35.812	29.601	6.211
10.155	35.554	28.1201	7.4339
16.722	38.807	28.2581	10.5489
21.546	42.704	30.35	12.354
26.133	47.277	33.2375	14.0395
31.896	53.525	37.3995	16.1255
37.831	60.417	42.182	18.235
43.839	68.404	47.5543	20.8497
49.864	76.81	53.3542	23.4558
55.982	85.409	59.5411	25.8679

62.175	94.845	66.0926	28.7524
68.378	104.507	72.8776	31.6294
74.616	113.686	79.7245	33.9615
80.95	123.927	87.0121	36.9149
87.137	133.879	93.9651	39.9139
93.323	133.814	98.4125	35.4015
100.16	125.473	100.202	25.271
113.83	125.854	101.004	20.538

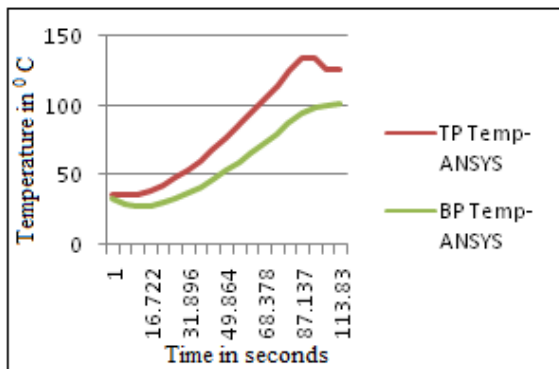

Fig. 27 Effect of Square sandwich cell geometry on the heat-insulation performance honeycomb TPS panel

Comparison between right hexagonal structure and square structure

When the heat insulating performance of the honeycomb sandwich panels have been reasonably well-known, good agreement has been obtained between ANSYS and Experimental results. Some success has been attained in determining uncertain structural characteristics by attempting to match ANSYS and experimental results. For the most part, effort has been concentrated on determining the temperature variation of right hexagonal panel and square panel with respect to time. Table-4 shows a comparison of ANYSIS and experimental results for temperature difference. Aluminum hexagonal honeycomb structure for heat insulating is better than square honeycomb structure

Table- 4 Heat Insulating performance of TPS honeycomb-panel with different cell geometry

S No	Cell type	Material	Time in sec	Maximum Δt Values (max. heat shield)	
				Experimental	ANSYS
1	Right Hexagonal	Aluminum-2024	86.36	50.581	49.6572
2	Square	Aluminum-2024	87.137	-----	39.9139

Conclusion

The geometrical (shape) analysis of different candidate honeycomb cells that have the same effective density but different cell geometrical shapes. Heat-transfer, analysis are performed on a aluminum alloy thermal protection system (TPS) for future vehicles. Effect of honeycomb cell geometry on the heat-insulating performance, are fin out. Infra-red experiment was conducted to investigate the response of several areas of the shield during the flight. The Aluminum alloy specimen researches its temperature limits in 90 seconds. For aerospace use, it is desirable to use the material which can attain its temperature limit after the elapse of more time. The heat-insulating performance of a honeycomb TPS is insensitive to the shape of the honeycomb cell under the same effective core density, but improves with the core depth.

References

1. Thermostructural Analysis of Honeycomb Sandwich Panels, K.Kantha Rao, K. Jayathirtha Rao, International Journal of EngineeringScience&Advanced Technology, volume-2, issue-5 Sep-Oct2012.
2. Strength Analysis on Honeycomb Sandwich Panels of different Materials K.Kantha Rao, K. Jayathirtha Rao, A.G.Sarwade, M.Sarath Chandra, International Journal of engineering research and applications volume 2, issue 3, May-Jun 2012,
3. Shigenori Kabashima & Tsuyoshi Ozaki, Numerical Approach to calculate thermal expansion of Honeycomb sandwich panel with composite face sheets, Advanced Composite Materials, Apr 2012.

4. J. Fatemi Dutch Space, 2303 DB Leiden, The Netherlands and M. H. J. Lemmen Effective Thermal/Mechanical Properties of Honeycomb Core Panels for Hot Structure Applications, Journal of Spacecraft and rockets vol. 46, No. 3, May–June 2009
5. P. Innocenti and F. Scarpa Thermal Conductivity Properties and Heat Transfer Analysis of Multi-re-entrant Auxetic Honeycomb Structures, Journal of Composite Materials 2009 43: 2419, August 2009